

COLOR PAPERLESS RECORDER

INSTRUCTIONS

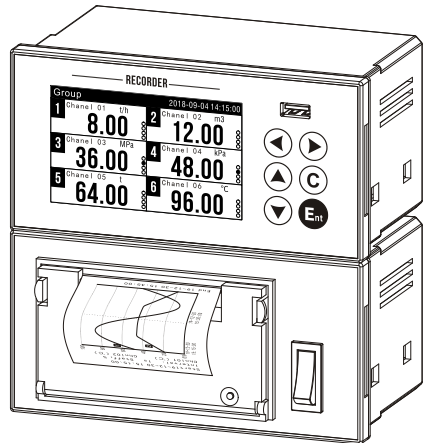
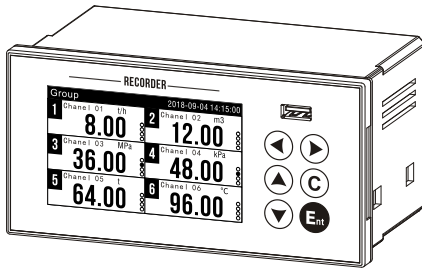

Preface

Thank you for buying our products. This specification describes the information required for product use, including product identification, storage, installation, commissioning, electrical connections, operation settings and troubleshooting. This product is an industrial paperless recorder with 6 channels universal input. It can receive signals such as current, voltage, thermocouple and thermal resistance, display them in real time and store the data in the internal electronic memory. The device can quickly transfer the history data through the USB interface.

Features:

- 6-Channel input, 6-Channel alarm
- 2-Loop transmitter, 2-Loop 24VDC output
- 4-inch 800X480 pixels color LCD display
- 128Mb Memory 900,000 history records
- 256 records of alarm record/power-down/log
- High speed USB Interface

Safety instructions

● Installation and Environment of the Instrument.

Please do not put the instrument in a place where there are flammable gases and steam to run and store.

● Reliable grounding is necessary.

In order to prevent the occurrence of electric shock accidents, before closing the power switch, it is necessary to confirm that the grounding of the instrument is effective and reliable.

● Turn off the power supply when there is a fault.

When the instrument has abnormal odor, sound, smoke, shell temperature rise, please cut off the power supply.

● Do not repair or alter this instrument by yourself.

Table of contents

1 Unpacking.....	2
2 Dimensions and mounting.....	3
3 Electrical connection.....	4
3.1 Terminal layout.....	4
3.2 Power supply.....	4
3.3 Inputs.....	5
3.4 24VDC Output.....	5
3.5 Relays.....	5
3.6 RS485.....	5
3.7 Transmitter.....	5
3.8 Micro-printer.....	5
4 Recording function.....	6
5 Function and Operation.....	7
5.1 Keyboard.....	7
5.2 Login.....	7
5.3 Display.....	8
5.4 History curve.....	9
5.5 Power-down/Alarm/System log.....	9
5.6 Data backup.....	10
5.7 Data editing.....	11
6 Micro-printer(Integrated).....	12
7 Configuration.....	14
7.1 System configuration.....	14
7.2 Input configuration.....	15
7.3 Alarm configuration.....	17
7.4 Communication configuration.....	18
7.5 Analog output configuration.....	19
7.6 Print configuration.....	19
8 PC Software.....	20
9 Trouble shooting.....	21
9.1 No data.....	21
9.2 No response of USB.....	21
9.3 Display #####/----.....	21
10 Specification.....	22

1 Unpacking

Confirmation of type and packing content

Before opening the packing box, confirm whether the packing is damaged or not; after opening the packing, if you find that there is a wrong model, quantity or physical damage on the appearance, please contact our company or the distributor who sells this product. The contents of packing are as follows:

Name	Quantity
Paperless Recorder	1
Mounting bracket	2
User Manual	1

Product identification (nameplate)

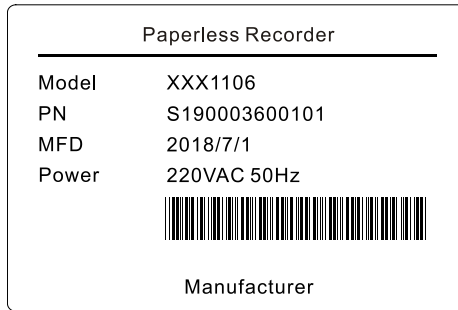

Notice: Please check the power specifications according to the order model and make sure that the type of power supply is 220V AC or 24V DC in order to avoid damaging the instrument.

2 Dimensions and mounting

This product is designed as an indoor panel mounting instrument.

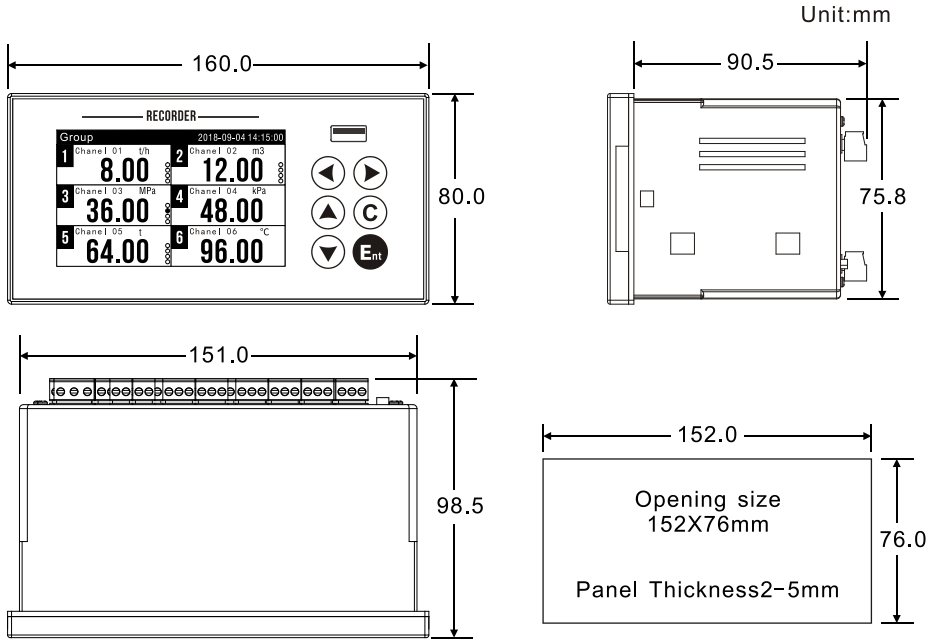

3 Electrical connection

The analog signal input of this product is universal signal input(not include frequency). Before wiring the instrument, please pay attention to:

- Please operate when the instrument is powered off.
- Make sure the ground wire is connected before wiring.

3.1 Terminal layout

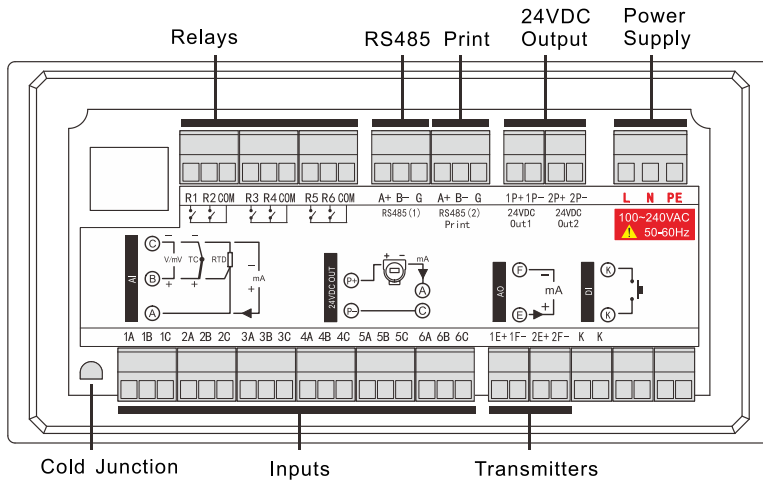

3.2 Power supply

L **N** **PE** : AC 110V/220V connect to L and N, PE connect to earth.



24V+ **24V-** : 24VDC connect to 24V+ and 24V-, with reverse protection.



3.3 Inputs

1A **1B** **1C** is first channel, **2A** **2B** **2C** is second channel,
X **Y** is frequency input terminal.

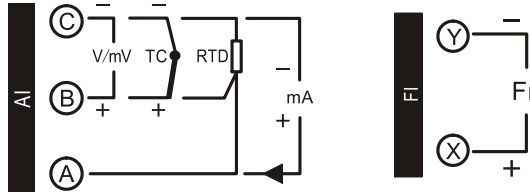

3.4 24VDC Output

P1+ **P1-** is first loop,
P2+ **P2-** is second loop..

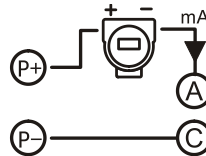

3.5 Relays

R1 - **R6** is relay contract, **COM** is common point.

3.6 RS485

A **B** **G**: indicators 485A+ 485B- GND.

3.7 Transmitter

4-20mA output E+ F-, **1E** **1F** is first channel, **2E** **2F** is second channel.

3.8 Micro-printer

A+ **B-** **G**: indicators 485A+ 485B- GND terminal of printer.

4 Recording function

● Data recording

The recorder records that sample data in real time according to the set time interval, and the recording interval can be selected as 1 second, 2 second, 5 seconds, 10 seconds, 15 seconds, 30 seconds, 1 minute, 2 minutes, 5 minutes, 10 minutes, 30 minutes and 1 hour; The default is 5 seconds.

The internal memory of the recorder can store 900,000 records, which are stored circularly. According to the recording interval and the total number of records, the recording time is calculated as follows:

Intervals	1s	5s	10s	1m	5m	10m
Duration	10d	50d	100d	600d	3000d	6000d

[NOTE]

- ◆ The recording time is independent of the number of channels.
- ◆ If the recording interval is changed, the history data will not be lost.
- ◆ If the channel signal or range is changed, the history data will change according to the range.
- ◆ If the power is not used, no history data will be generated.

● Other recording

At the same time, the recorder records channel alarm,down and operation logs, with 256 records each, which are stored circularly.

Alarm record includes alarm channel, type, status and time.

Instrument power failure includes power failure time, power-on time and duration.

Operation log includes entering configuration, modifying configuration, etc.

5 Function and Operation

5.1 Keyboard

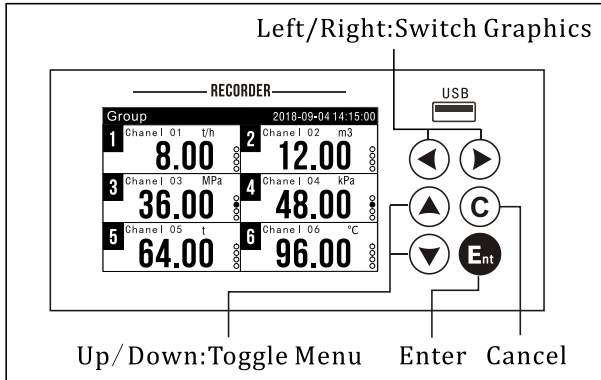

Right/Left key: Switch graphics

Up/Down key: Toggle menu entries

Enter key: Confirm or enter the menu, edit data

Cancel key: Return or cancel the current operation

5.2 Login

Press [Left and Right key] to switch to the query graphic, press [Up/Down key] to select the configuration, press [Enter key] to enter the login interface.



Enter the password, press [Enter key] to enter the configuration interface, the initial password is 0000.

5.3 Display

Display, left/ Right key to switch.

Data Display

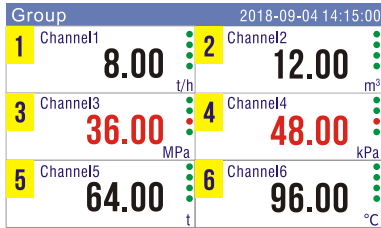

Enter key: Display signal

Patrol Display

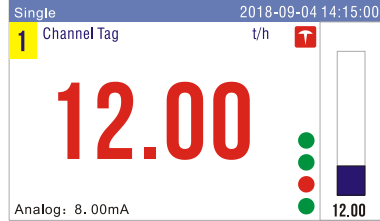

Up/Down key: Switch channel

Enter key: Fix display channel

Bar Display

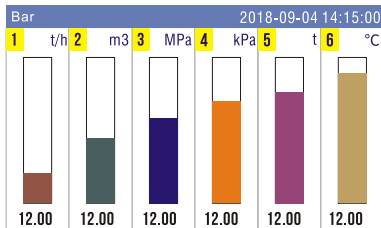

Real-time Curve Display

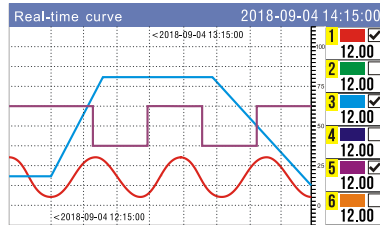

Up/Down key: Toggle channel selection

Enter key: Hide/show channel

Query

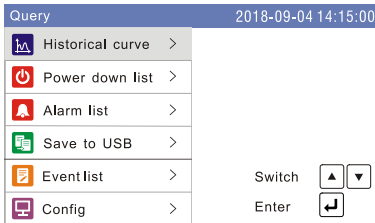

Up/Down key: Switch function

Enter key: Enter into

5.4 History curve

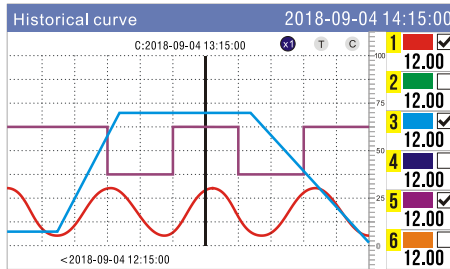

Left/Right key: Move cursor

Up/Down key: Switch function

Enter key: Execution

Zoom 1/2/4/8 Times

Query by date time

Show/Hide cursor

Show/Hide channel

5.5 Power-down/Alarm/System log

Power down list				2018-09-04 14:15:00
NO.	Power down	Power on	Timespan	
1	18-08-01 12:00:00	18-08-01 13:00:00	1h0m0s	
2	18-08-02 12:00:00	18-08-02 13:10:00	1h10m0s	
3	18-08-03 12:00:00	18-08-03 13:20:00	1h20m0s	
4	18-08-04 12:00:00	18-08-04 13:30:00	1h30m0s	
5	18-08-05 12:00:00	18-08-05 13:40:00	1h40m0s	
6	18-08-06 12:00:00	18-08-06 13:50:00	1h50m0s	
7	18-08-07 12:00:00	18-08-07 13:00:00	1h0m0s	
8	18-08-08 12:00:00	18-08-08 13:00:00	1h0m0s	
9	18-08-09 12:00:00	18-08-09 13:00:00	1h0m0s	
10	18-08-10 12:00:00	18-08-10 13:00:00	1h0m0s	

Alarm list						2018-09-04 14:15:00
NO.	Channel	Type	Status	Time		
1	1	LO	Alarm	18-08-01 12:00:00		
2	1	LO	Elimination	18-08-02 12:00:00		
3	1	LO	Alarm	18-08-03 12:00:00		
4	1	LO	Elimination	18-08-04 12:00:00		
5	1	LO	Alarm	18-08-05 12:00:00		
6	1	LO	Elimination	18-08-06 12:00:00		
7	1	LO	Alarm	18-08-07 12:00:00		
8	1	LO	Elimination	18-08-08 12:00:00		
9	1	LO	Alarm	18-08-09 12:00:00		
10	1	LO	Elimination	18-08-10 12:00:00		

Event list			2018-09-04 14:15:00
NO.	Time	Event	
1	18-08-01 12:00:00	Login	
2	18-08-02 12:00:00	Changing time	
3	18-08-03 12:00:00	Modified interval	
4	18-08-04 12:00:00	Factory Setting	
5	18-08-05 12:00:00	Export	
6	18-08-06 12:00:00	Changing password	
7	18-08-07 12:00:00	Login	
8	18-08-08 12:00:00	Login	
9	18-08-09 12:00:00	Login	
10	18-08-10 12:00:00	Login	

There are 256 records of power down, alarm and system logs respectively.

[Left/Right Keys] Page-turning browse,

[Up/Down Keys] Single line browse,

[Cancel Key] Exit.

5.6 Data backup

After inserting the USB stick, it will automatically go to the data transfer function interface or enter through the function query interface.

[Enter key] Performs data transfer function.

- ◆ Files are named by date, such as 180904A. PLR
- ◆ File output directory is PLR Directory
- ◆ Using Paperless Recorder Software (PLR. EXE)
- ◆ Data includes history data, power-down record, alarm record and operation log.
- ◆ Firmware upgrade function, please contact the manufacturer

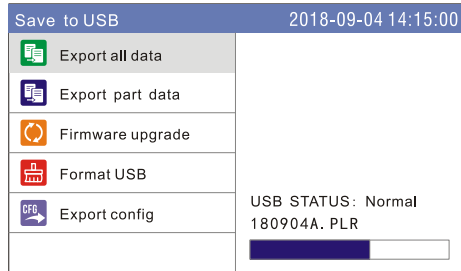

- Export config

Export config to USB-Stick, import config an system config menu.

5.7 Data editing

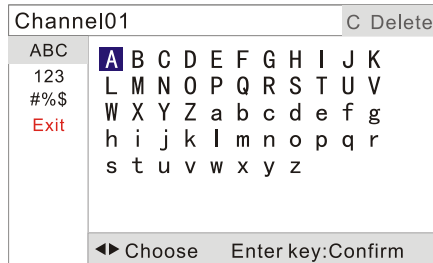

The input method is used in text editing. On the left, [up and down keys] switch the classification and alphabet, on the right, [left and right keys] move the text cursor, [confirmation keys] select the text, [Cancel C keys] delete the text.

Exit: [Up and down key] Select red exit category, save exit or not.

6 Micro-printer(Integrated)

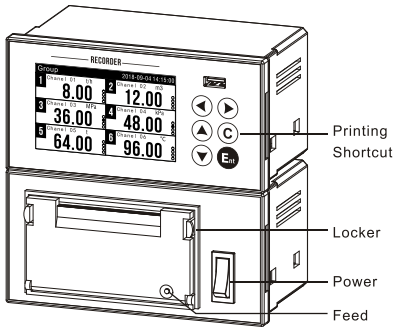

Print Mode: Ribbon printer
 Print Paper: Roller paper, 57mm wide, 30mm diameter
 Print Width: 48mm wide valid
 Operating Environment:
 T:0-50°C H:10-85%RH

1、Automatic printing

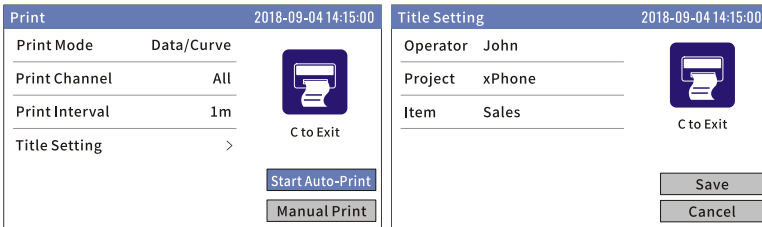

Print Mode: Numeric or curve.

Print Chnl: Chnl1-6 or All.

Print Interval: The Numeric print interval is in minutes, from 1 to 120 minutes;
 The curve print interval is in seconds, from 1 to 120 seconds.

Title Setting: Titles, maximum 3 titles, 16 chars.

Start Auto-Print: Turn on automatic printing, and an icon appears in the title bar;
 Click again to stop automatic printing.

Manual Print: Enter into manual print interface.

2、Manual printing

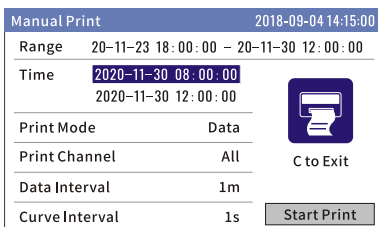

Range: Range of history data.

Time: Time range for printing.

Print Mode: Numeric/Curve/
 Numeric+Curve.

Print Chnl: Chnl1-6 or All.

Numeric Intvl: The Numeric print

interval is in minutes, from 1 to 120 minutes.

Curve Intvl: The curve print interval is in seconds, from 1 to 120 seconds.

Start Print: Start manual printing and click again to stop.

3、Print example

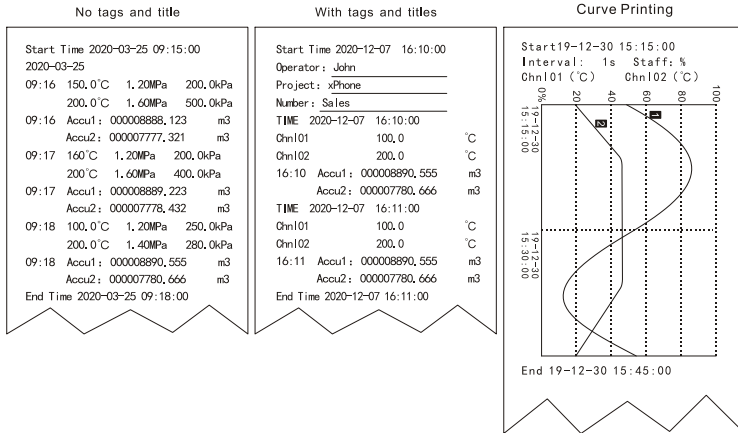



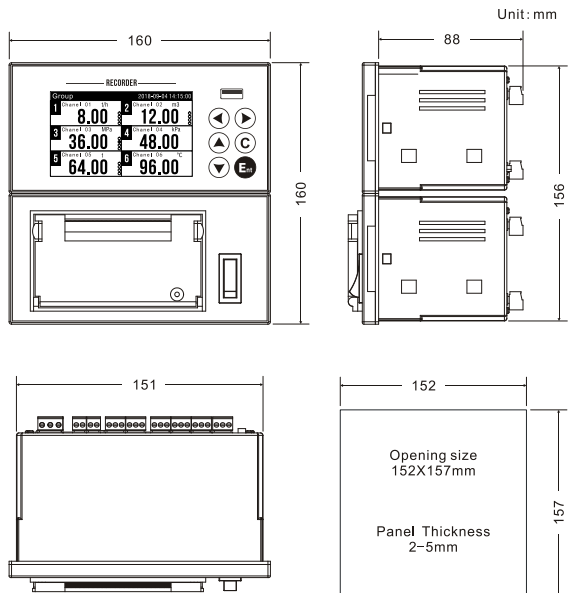



4、Dimension









7 Configuration

7.1 System configuration

Configuration		2018-09-04 14:15:00
 System >	Datetime	18-09-04 16:21:00
 Input >	Language	English >
 Alarm >	Password	0000 >
 Comm. >	Record interval	5s >
 AO >	Cold-junction	Auto 20.0 >
 Print >	Buzzer	ON >

Date Time	System Date and Time
Language	English/Chinese
Password	0000
Record Interval	1s 2s 5s 10s 15s 30s 1m 2m 5m 10m 30m 1h; default 5s.
Cold-junction	Automatic or Manual.
Buzzer	OFF/ON The sound of key.
Factory settings	Reset all parameter to default.
Export Config	Export configuration to USB Stick
Import Config	Import configuration from USB stick

7.2 Input configuration

Configuration		2018-09-04 14:15:00
 System >	Channel	01
 Input >	Display	ON >
 Alarm >	Tag	Channel01 >
 Comm. >	Signal type	Current >
 AO >	Signal	4-20mA >
 Print >	Unit	°C >

Channel	Channel index. Long press Enter key to copy current channel parameter to all channel.
Display	ON/OFF; Display switch.
Tag	Channel tag, maximum 16 characters.
Signal Type	Current/Voltage/mV/Voltage/V/TC/RTD/Simulation
Signal	See appendix Signal Type, default 4-20mA.
Unit	See appendix Channel Uni, default °C.
Decimal point	0-3, default 2.
Scale	-999999~999999, default 0.00-100.00. Vacuum mode, value is exponent, range -5~5.
K	Multiple, default 1.00.
B	Addition/Subtraction, default 0.00.
Burnout	####/Scale H/Scale L/Keep, default ####.
Filter	Inertial filter, 0.0-9.9s, default 0.0s.
Excision	Weak signal excision, 0.0-9.9%, default 0.0%.
Vacuum	OFF/A1/A2; A1:Exponential and signal linear proportion algorithm; A2:The index is divided into 10 segments, and the linear proportion algorithm of the value and signal in the segment
Accu	OFF/ON; default OFF.
Accu K	When flux unit is X/h, K equals 1.0; When flux unit is X/min, K equals 60.
Accu Unit	Kg/t/L/m ³ /km ³ /Nm ³ /kNm ³ (Just display)
Clear Accu	Clear the accumulation







Appendix: Signal Type

Current	4-20mA/0-20mA/0-10mA/4-20mA Sqrt
Voltage mV	0-100mV/0-20mV
Voltage V	0-5V, 0-10V/1-5V
TC	K/S/B/J/R/N/T/E/WRe3-25/WRe5-26/F1/F2
RTD	Pt100/Cu50/Cu53/Cu100
Fr	0-10000Hz (Customize)
Simulation	SIN/COS

Appendix: Channel Unit







°C	°F	kg/h	t/h
m ³ /h	km ³ /h	L/h	Nm ³ /h
kNm ³ /h	bar	mbar	mmH ₂ O
mmHg	Pa	kPa	MPa
atm	kgf/cm ²	mm	cm
m	km	Wh	kWh
W	kW	MW	kJ
Hz	kHz	MHz	g
kg	t	mV	V
kV	mA	A	kA
kJ/h	MJ/h	GJ/h	ppm
ppb	%	‰	ppmO ₂
ppmH ₂	%O ₂	%LEL	NTU
ug/h	ug/kg	rpm	uS/cm
mS/cm	MOcm	r/min	pH
%RH	N	mg/L	g/L
kg/m ³	kcal/m ³	m/min	m/s
mg/m ³	°	cm/min	

7.3 Alarm configuration

Configuration		2018-09-04 14:15:00
 System >	Channel	01
 Input >	Status	OFF >
 Alarm >	Relay delay	0S >
 Comm. >	Backlash	1.00 >
 AO >	Alarm Low	20.00 >
 Print >		Relay01 >

Channel	Channel Index.
Status	OFF/ON, default OFF.
Relay delay	The delay time of relay action, 0-60s.
Backlash	0-99999, Within the difference between the alarm limit and the return difference, the alarm is eliminated.
Alarm Type	4-Type: LL/Lo/Hi/HH.Vacuum mode, value is exponent, range -5~5.
Relay	Relay index 1-6.

7.4 Communication configuration

Configuration		2018-09-04 14:15:00	
 System >	Address	001 >	
 Input >	Baudrate	115200 >	
 Alarm >	Parity	None >	
 Comm. >	Byte swap	2143 >	
 AO >			
 Print >			

Address	1-247; Modbus-RTU slave device address.
Baud rate	9600/19200/38400/57600/115200, default 9600.
Parity	None/Odd/Even, default None.
Byte swap	float data byte swap order, default 2143.

32bits float data(4XXXX: 03 Command)

Channel	Offset	Reg Addr	Channel	Offset	Reg Addr
Channel1	0000H	40001	Channel4	0006H	40007
Channel2	0002H	40003	Channel5	0008H	40009
Channel3	0004H	40005	Channel6	000AH	40011

Example: Read data of channel 1(32bits, float)

Query: 01 03 00 00 00 02 C4 0B

Response: 01 03 04 00 00 41 A4 CB D8

Analyze:[00 00 41 A4] => 20.50

32bits signed long data (3XXXX: 04 Command)

Channel	Offset	Reg Addr	Channel	Offset	Reg Addr
Channel1	0000H	30001	Channel4	0006H	30007
Channel2	0002H	30003	Channel5	0008H	30009
Channel3	0004H	30005	Channel6	000AH	30011







Example: Read data of channel 1(32bits signed long)

Query: 01 04 00 00 00 02 71 CB

Response: 01 04 04 00 00 03 E8 FB 3A







Analyze:[00 00 03 E8] => 100.0(1decimal point, same with channel setting)

7.5 Analog output configuration

Configuration		2018-09-04 14:15:00
 System >	AO channel	01 >
 Input >	Src channel	01 >
 Alarm >		
 Comm. >		
 AO >		
 Print >		

AO Channel	AO channel index
Src Channel	Source channel, 0 represents OFF.

7.6 Print configuration

Configuration		2018-09-04 14:15:00
 System >	Channel Tag	ON >
 Input >	Print Time	ON >
 Alarm >	Curve Staff	%
 Comm >	Title 1#	Operator >
 AO >	Title 2#	Project >
 Print >	Title 3#	Item >

Chnl Tag	ON/OFF
Print Time	ON/OFF
Curve staff	%/Channel
Title1#~3#	8 letters length, will not print when empty.

8 PC Software

The file of the recorder is opened by the PC software PLR. EXE.

The software installation package can be obtained from the USB stick. The software icon is as follows.



PLR.EXE

The software operation interface is as follows.

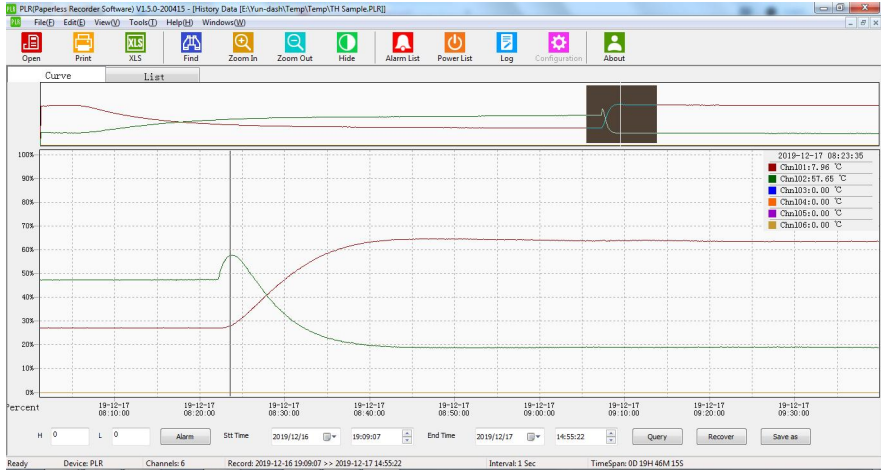

Index	Time	Chan01 [°C]	Chan02 [°C]	Chan03 [°C]	Chan04 [°C]	Chan05 [°C]	Chan06 [°C]
1	2019-12-16 19:09:07	-20.00	0.00	0.00	0.00	0.00	0.00
2	2019-12-16 19:09:12	42.09	20.02	0.00	0.00	0.00	0.00
3	2019-12-16 19:09:17	42.09	19.94	0.00	0.00	0.00	0.00
4	2019-12-16 19:09:22	42.09	19.83	0.00	0.00	0.00	0.00
5	2019-12-16 19:09:27	41.99	19.94	0.00	0.00	0.00	0.00
6	2019-12-16 19:09:30	41.93	19.89	0.00	0.00	0.00	0.00
7	2019-12-16 19:09:31	42.08	19.89	0.00	0.00	0.00	0.00
8	2019-12-16 19:09:32	42.09	19.83	0.00	0.00	0.00	0.00
9	2019-12-16 19:09:33	42.09	19.83	0.00	0.00	0.00	0.00
10	2019-12-16 19:09:34	42.09	20.02	0.00	0.00	0.00	0.00
11	2019-12-16 19:09:35	42.09	20.02	0.00	0.00	0.00	0.00
12	2019-12-16 19:09:36	42.08	20.02	0.00	0.00	0.00	0.00
13	2019-12-16 19:09:37	41.93	19.73	0.00	0.00	0.00	0.00
14	2019-12-16 19:09:38	41.93	19.73	0.00	0.00	0.00	0.00
15	2019-12-16 19:09:39	42.09	19.73	0.00	0.00	0.00	0.00
16	2019-12-16 19:09:40	42.09	19.73	0.00	0.00	0.00	0.00
17	2019-12-16 19:09:41	42.09	19.73	0.00	0.00	0.00	0.00
18	2019-12-16 19:09:42	42.09	19.83	0.00	0.00	0.00	0.00
19	2019-12-16 19:09:43	42.09	19.83	0.00	0.00	0.00	0.00
20	2019-12-16 19:09:44	42.08	19.83	0.00	0.00	0.00	0.00
21	2019-12-16 19:09:45	42.08	19.83	0.00	0.00	0.00	0.00
22	2019-12-16 19:09:46	42.09	19.73	0.00	0.00	0.00	0.00
23	2019-12-16 19:09:47	42.09	19.73	0.00	0.00	0.00	0.00
24	2019-12-16 19:09:48	42.09	19.73	0.00	0.00	0.00	0.00

9 Trouble shooting

9.1 No data

- (1) Check whether the electrical wiring is correct
- (2) Check that the signal type is set correctly
- (3) Press [Enter Key] to display the original signal value

Group		2018-09-04 14:15:00	
1	Channel Tag	8.00	2 Channel Tag
Analog:8.00mV		t/h	Analog:12.00mA m ³
3	Channel Tag	36.00	4 Channel Tag
Analog:8.00mV		MPa	Analog:12.00mA kPa
5	Channel Tag	64.00	6 Channel Tag
Analog:8.00mV		t	Analog:12.00mA °C

9.2 No response of USB

Format the USB stick with FAT32, then try again.

9.3 Display #####/-----

The burnout flag, please check whether the configuration and electrical connection are correct.

---- In order to give an alarm beyond the limit, it means that the signal value exceeds the upper limit of the measuring range. Please check the output signal to avoid damaging the instrument.

10 Specification

Category	Signal	Measuring range		Accuracy
Current	4-20mA	4.00~20.00mA		±0.2%
	0-20mA	0.00~20.00mA		±0.2%
	0-10mA	0.00~10.00mA		±0.2%
Voltage mV	20mV	0.00~20.00mV		±0.2%
	100mV	0.00~100.00mV		±0.2%
Voltage V	0-5V	0.000~5.000V		±0.2%
	0-10V	0.00~10.00V		±0.2%
	1-5V	1.000~5.000V		±0.2%
TC		Separation	Not Separation	
	K	-200~1372°C	T _{CJ} ~1372°C	±2°C
	S	-50~100°C	T _{CJ} ~100°C	±4°C
		100~1768°C	100~1768°C	±3°C
	B	250~500°C	250~500°C	±5°C
		500~1820°C	500~1820°C	±3°C
	J	-210~1000°C	T _{CJ} ~1000°C	±2°C
	R	-50~100°C	T _{CJ} ~100°C	±4°C
		100~1768°C	100~1768°C	±3°C
	N	-200~1300°C	T _{CJ} ~1300°C	±3°C
	T	-200~400°C	T _{CJ} ~400°C	±2°C
	E	-200~1000°C	T _{CJ} ~1000°C	±2°C
	WRe3-25	0~2315°C	T _{CJ} ~2315°C	±5°C
	WRe5-26	0~2310°C	T _{CJ} ~2310°C	±5°C
F1	700~2000°C	700~2000°C	±2°C	
F2	700~2000°C	700~2000°C	±2°C	
RTD	Pt100	-200.0~650.0°C		±0.5°C
	Cu50	-50.0~140.0°C		±0.5°C
	Cu53	-50.0~150.0°C		±0.5°C
	Cu100	-50.0~150.0°C		±0.5°C
Fr	Fr	0~10000Hz		1Hz

[NOTE] T_{CJ}: The temperature of cold junction.

Environment: T 23±2°C H 55±10%RH

Project	Specification
Dimensions	Panel 160*80mm, opening 152*76mm, depth 100mm
Weight	450 grams
Installation mode	Panel-mounting, indoor
Channels	6-channel universal analog input
Sampling period	1second
Accuracy	0.2% F.S.
Temperature Drift	≤100PPM/°C
Power Supply EFT	Not separation: 1000V Separation: 2000V
Signal EFT	Not separation: 500V Separation: 1000V
ESD	Contact discharge 4000V Air discharge 8000V
Surge	AC: 2000V DC: 1000V
Limit voltage	Between input terminal: 400V; Between protect earth with input terminal: 1000V.
Insulation resistance	≥500MΩ
24VDC Output	2-Loop 24 VDC±10%, 30mA per loop
Alarm relay	6 relays, 250VAC 3A, 30VDC 3A (Normal open)
Analog output	2-Loop 4-20mA output Load < 750Ω Accuracy 0.2% F.S.
Power supply	AC 100~240 VAC 50Hz or 60Hz / DC 24VDC+10% 10W
Preheating time	30 minutes after power-on
Work environment	T: -10~60°C H: 0~85% RH (no condensation)
LCD screen	4 inch color LCD screen, 800*480 pixels
Record Interval	1s/2s/5s/10s/15s/30s/1m/2m/5m/10m/30m/1h
Data memory	16MB, 900, 000 records; 10days record duration with 1s recording interval, The other recording intervals have the same linear ratio.
Other records	256 alarm records, 256 power-down records, 256 operation logs
RS485	Standard Modbus-RTU Protocol
Print	Micro printer, RS485
USB	USB2.0

